

Let's take
a deep breath!



Commercial Kitchen Exhaust
Air Treatment System



ELX SERIES



ESPAIR Smoke-eater ELX Series

A well engineered Solution for Commercial Kitchens



Air quality is become a major concern; therefore Commercial kitchens need to treat the air emitted from cooking processes before exhausting into ambient. They require complying with the increasing demands of environmental control agencies apart from addressing the concerns of neighbors and property owners.

The **ESPAIR** Smoke-eater is ideal solution for the removal of grease and smoke from commercial cooking plumes. These systems work on the principles of “electrostatic precipitation” and are very efficient in getting rid of smoke, grease, mist and other particulate matters keeping pressure drop as minimal.

ESPAIR Smoke-eater ELX Series, the Right Solution

The Product...

Description

Prefilter, Electrostatic Cell and Postfilter are placed in series within an all metal housing. Contaminated air is drawn by the blower (external) through washable metal mesh pre-filter which traps large dust particles. Thereafter it passes through Electrostatic cell which traps fine particulate matter like oil, smoke and grease, then it exits inline through Postfilter. The solid contaminants are held on electrostatic cell until they are washed off. Liquid contaminants are collected in the bottom tray and can be drained out. All internals can be slide out through Side access door for periodic cleaning. Control Box is mounted on side access door which houses all Electrical components.

How Electrostatic Precipitators Work...

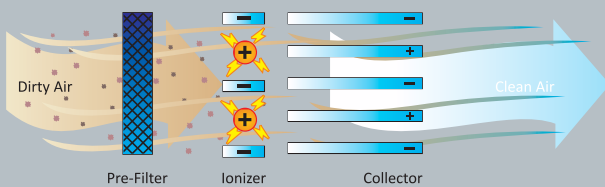

As air enters the filter, the particles pass through a high intensity electrical field that imparts an electrical charge to the particles, which range in size from 0.01 micron to 10 microns. The charged particles pass through a series of alternately charged collector plates. Particles are repelled by plates with the same polarity and attracted to plates with opposite polarity – similar to how a powerful magnet works.

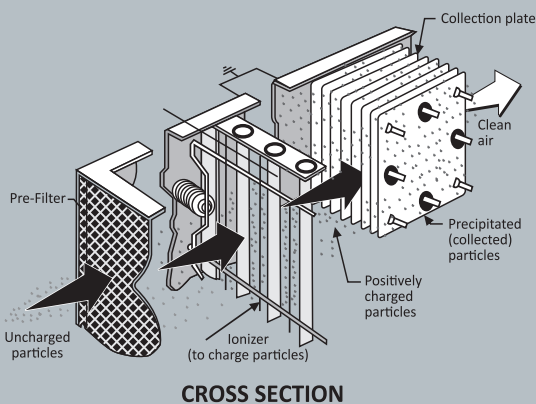

CROSS SECTION

Technicals...



ELX-1



ELX-2



ELX-3



ELX-4



ELX-5

Parameters	ELX-1A	ELX-2A	ELX-3A	ELX-4A	ELX-5A
Unit Size (HxWxL) - in mm	565x665x620	565x1165x620	565x1670x620	565x2170x620	565x2670x620
MOC	1.6 mm thick Galvanized Steel				
Finishing	3 mil thick Polyester Powder Coated				
Weight	58	92	126	161	195
Air Volume (Rated-Max)-CMH	2500-4600	5000-9200	7500-13800	10000-18400	12500-23000
Airflow Direction	Right to Left / Left to Right				
Static Pressure Drop	50 pa / 0.2"				
Safety	*Auto power cut-off when access door is opened. *Mechanical Main Switch interlock for Electrical Panel Power shuff-off				
Efficiency	*DOP Test- upto 95% single pass & upto 99% double pass. *ASHRAE 52.2-2012- upto 97% single pass & upto 99% double pass. *NIOSH 5026 OIL MIST FIELD TEST : UP TO 97%. *MERV Ratings Meets MERV 15.				
Particle Size	Particle size From 0.01 microns - 10 microns				
No. of Cell	1	2	3	4	5
Size of Electrostatic Cell	480x500x342 mm				
Weight of Electrostatic Cell	16 kg				
Type of Ionizer	Stainless Steel Double side Spiked Blade Ionizer				
Prefilter	Aluminum wire mesh, Washable				
No. of Prefilters	1	2	3	4	5
Afterfilter (Optional)	5 Ply Aluminum wire mesh Panel Type, Washable or Activated Carbon Honeycomb Filter				
No. of Afterfilters	1	2	3	4	5
Input Voltage/Frequency	200-260VAC/50-60Hz.				
Rated Input Current/Wattage	480mA/60W	960mA/120W	960mA/120W	1.60A/200W	1.60A/200W
HV-SMPS - Output Voltage	Dual output. 12KVDC for Ioniser/6KVDC for Collector. Positive Polarity (Default). ± 10% output voltage adjustment using a potentiometer				
HV-SMPS - Output Power	45W	80W	115W	155W	190W
HV-SMPS - Output Metering (Optional)	Actual output voltage & current measurement readouts to be provided in terms of 0 to 5V / 0 to 2V analogue signals.				
HV-SMPS - Indications	A potential free relay contacts provided for BMS/ HV Output Status Indication.				
Protections	Short Circuit: During short circuit, the output current shall be restricted at predefined set value less than 3 times the rated current to avoid load cell damage. Over-Current: In case load draws over-current, the output shall remain at predefined set value as similar in short circuit condition. Arc/Spark Protection: In case of an arc or spark, output enters into hiccup mode, output be switched off momentarily & restore itself automatically.				
Certifications/Harmonics /EMI & EMC	CE marked and with RoHS for EMI, EMC & safety guidelines. Able to suppress the major harmonics, complied to EN61000-3-2 ClassA.				
Add-on Ozone UV Lamps (Optional)	1x40w	1x75w	2x75w	2x75w	2x90w
Installations	Installation Ceiling Suspended; Wall or Frame Mounted, Multiple Units Stacked				

Systems Layout

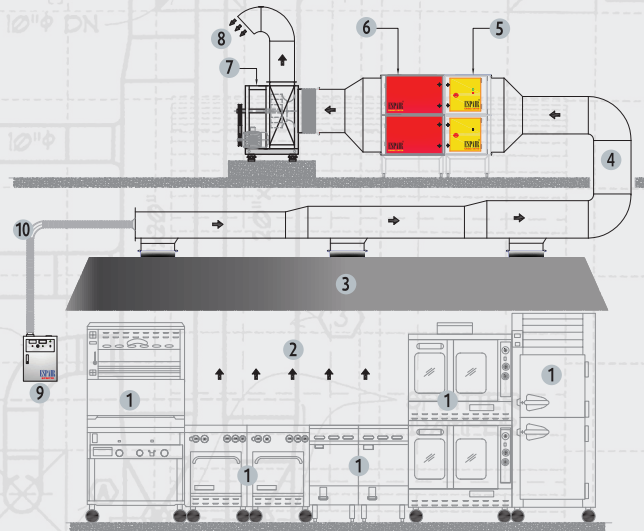

- 1 Kitchen Equipments
- 2 Cooking Plume
- 3 Exhaust Canopy (Hood)
- 4 Metal Air Ducts
- 5 Espair Smoke Eater
- 6 Espair Odor Remover
- 7 Exhaust Fan
- 8 Clean Air
- 9 Espair Ozonia-OG
- 10 Ozone Injection Pipe

Unit Dimension

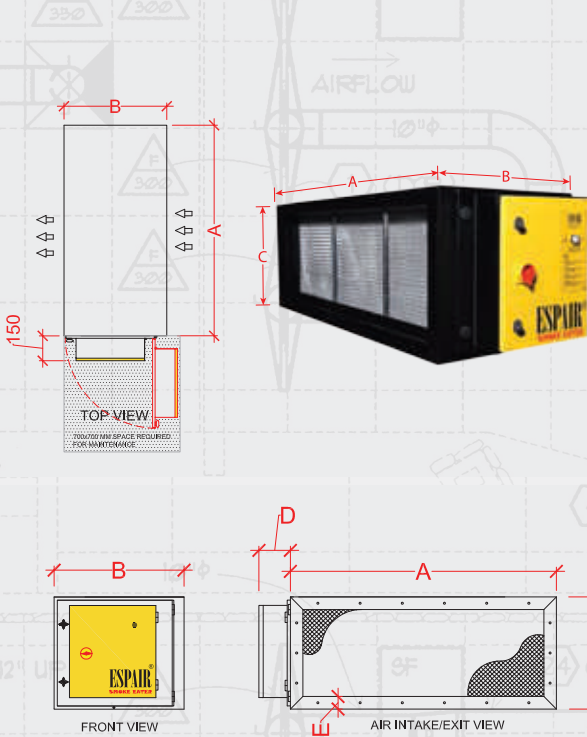

Typical System Arrangements

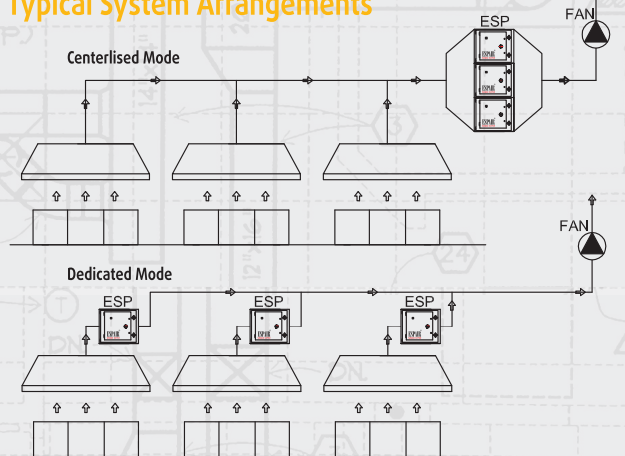

	A	B	C	D	E
ELX-1	515	620	565	150	60
ELX-2	1015	620	565	150	60
ELX-3	1520	620	565	150	60
ELX-4	2020	620	565	150	60
ELX-5	2520	620	565	150	60

All Dimension are in mm

Features & Benefits

Incorporating the latest advanced technology design and manufacturing technology, ESPAIR ELX-series bring to the customer even greater operational, maintenance and Efficiency benefits.

SMOKE AND ODOR CONTROL

Components effectively remove both liquid and solid particulate, as well as gas and odor.

HIGH EFFICIENCY CLEANING

Up to 99% efficient, per DOP & ASHRAE test methods.

LOW PRESSURE DROP

Very low pressure drop in comparison to media and cartridge filter, thereby saving fan energy.

FIRE SAFE

Designed to NFPA 96 standards for kitchen exhaust.

CONSTRUCTION QUALITY

High quality construction adhering to international standards.

HEAVY DUTY ELECTROSTATIC CELL DESIGN

The most durable and efficient cell design on the market insures long term performance and reliability. Highly efficient and easy to maintain at the same time.

HIGH VOLTAGE SMPS

New generation HV-SMPS based on Frequency Modulation with CV & CC Loops for Uniform Corona formation. KV and mA metering can be offered as an option.

SS SPIKED IONIZER SAWTOOTH DESIGN

Efficient Charging with unique ionizer design. Unlike Wire Ionizers no problems of wire breakage and lower corona intensity. Increased system reliability and Reduces maintenance/replacement cost.

PTFE INSULATOR

- Increased reliability and performance.
- Prevents cracks and imperfections.
- High surface area than standard insulators.

SIMPLE TO SERVICE

Designed for easy serviceability. Like e-Weldless/Jointless 50 mm deep Drain Pan and easy access to control panel etc.

EASE OF INSTALLATION

System design makes installation simple and requires no field assembly. Just attach your ductwork, electrical connection and plumbing, and it's done.

MODULAR/SECTIONAL DESIGN

Built-up modular design allows units to be stacked to your exact requirements.



ASHRAE 52.2

ASHRAE 52.2-2012 Test Report

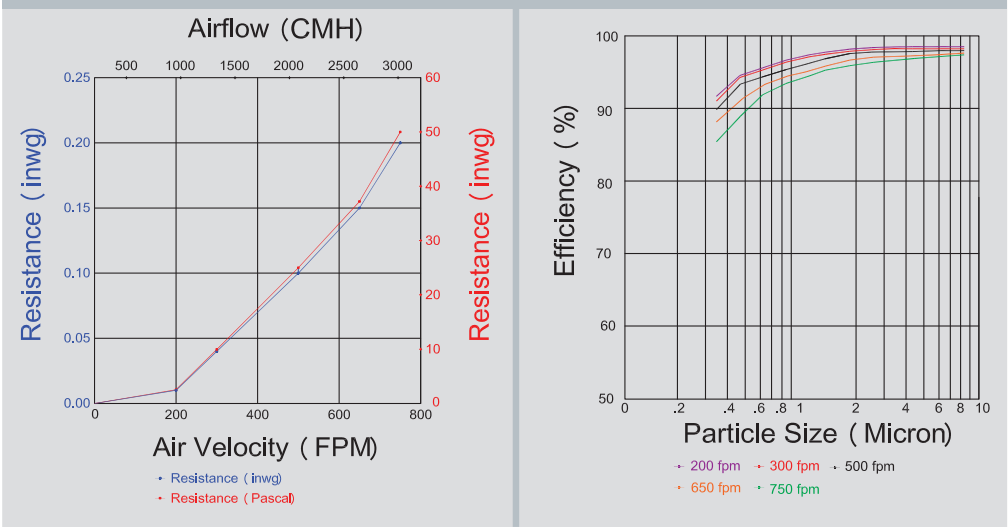

ASHRAE 52.2-2012 - Initial Particle Removal Efficiency (%) and Air Resistance (inwg)					
Average Particle Size	Air Velocity - FPM				
	@200	@300	@500	@650	@750
E1 (0.3 – 1.0 µm)	95	95	93	92	92
E2 (1.0 – 3.0 µm)	97	97	96	95	94
E3 (3.0 – 10.0 µm)	98	98	97	96	95
Resistance - inwg	0.01	0.04	0.10	0.15	0.20

DOP Test

DOP Efficiency - Initial Particle Removal Efficiency (%)					
Average Particle Size	Air Velocity - FPM				
	@200	@300	@500	@650	@750
0.3 – 0.5 µm	92.0	91.4	88.5	84.9	82.4
0.5 – 0.7 µm	93.8	93.6	92.9	91.2	89.3
0.7 – 1.0 µm	95.4	94.9	93.8	92.6	91.2
1.0 – 2.0 µm	96.3	95.5	94.5	93.4	93.1
2.0 – 5.0 µm	96.9	96.1	95.0	94.6	94.2

Other Tests

Other Tests	
EN779	Tested for EN779 with DEHS Aerosol for 0.4 Micron Particulate Matters and attained rating equivalent to F8
NIOSH 5026 Test	Field tested for this Airborn Mineral Oil Mist Test and attained more than 96%
ISO 16890	Equivalent to ISO ePM1 93%
MERV Ratings	Equivalent to MERV 15
ASHRAE 52.1	Arrestance found to be more than 99%



“ Our goal is to be the market leader with our **ESPAIR**® products. In addition to our competence in development and manufacturing, we strive for a culture of communication and customer service, which links your requirements with our solutions. The promise of the **ESPAIR**® sales team is to be this link - from the first contact right to the end of the project. ”



Tested for ASHRAE Std.,
EN: 779-2012 and DOP Efficiency



Tested and Certified for LVT and EMC



Proudly Manufactured in India



Manufactured and Marketed by

ESPAIR LLP

Regd. Office : #219, Sector-19, Faridabad-121002 (HR), INDIA
Work : Plot No. 20, Gali No. 2, Gurukul Industrial Area, Faridabad (HR)
Tel. : +91 129 4004643, +91 9810124643, +91 9818594590
Email : espaircorp@gmail.com, espairllp@gmail.com
Web : www.espair.co.in

www.espair.co.in